

Both the Pyrogen Generator & the heat Sensor are terminated back to the FirePak FACP Control Panel, which once a signal is received from the sensor, will activate Alarms/Sounders, Main fire control systems & the Pyrogen Generator.

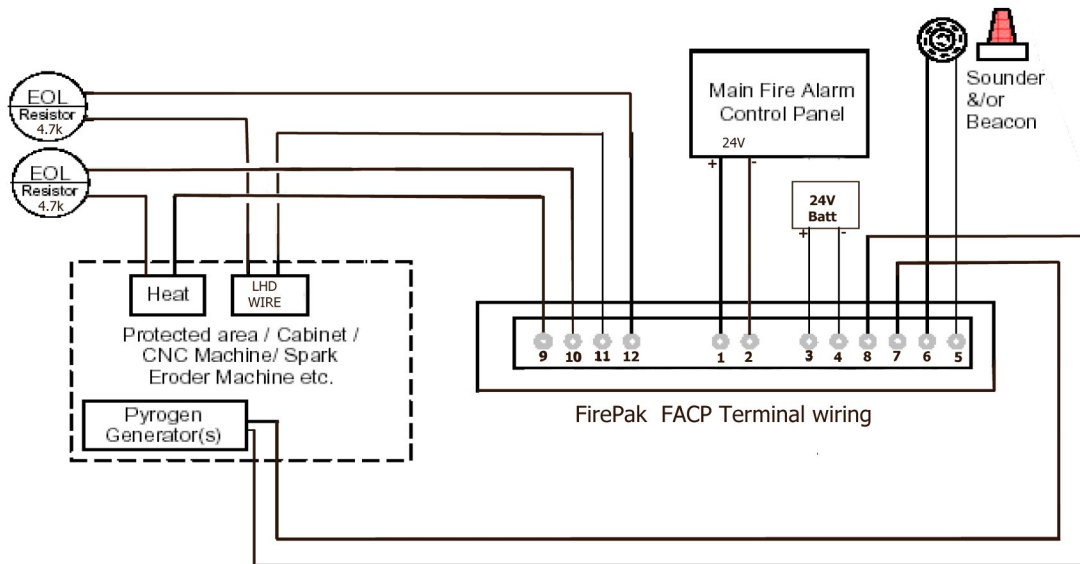

**FirePak Oil and Gas Industries**  
**7171 Harwin Dr Suite 316**  
**Houston Tx 77036**  
**P 713 952 1996 F 713 952 1997**

Product Name.  
**CNC/ Spark Eroder Enclosure Protection System**

File Name: CNC/Spark E Layout Date: 28<sup>th</sup> September 2005