

Both the Pyrogen Generator & the heat Sensor are terminated back to the PyroSense II Control Panel, which once a signal is received from the sensor, will activate Alarms/Sounders, Main fire control systems & the Pyrogen Generator.

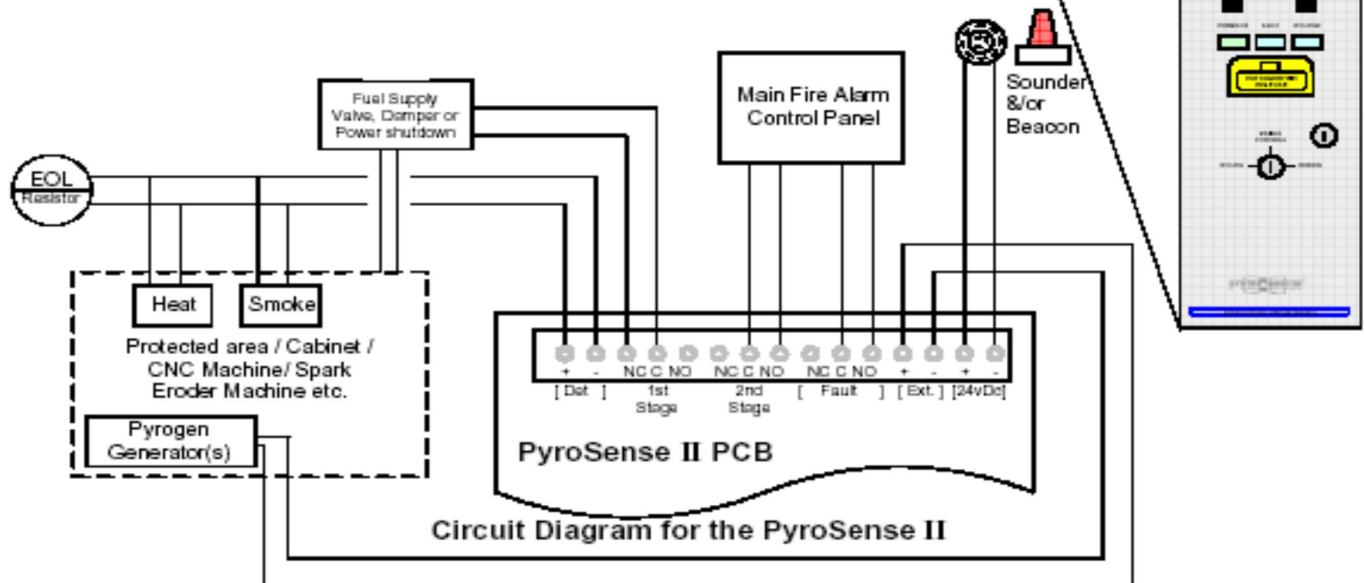

FirePak Oil and Gas Industries
 7171 Harwin Dr Suite 316
 Houston, TX. 77036
 P713 952 1996 F 713 952 1997
<http://www.pyrogen.com>

Product Name. PCNC-x-B
 CNC/ Spark Eroder Enclosure
 Protection System

File Name: CNC/Spark E Layout Date: July 07, 2006